



West Pharmaservices

Process and Packaging Machinery Engineers



Penta



CASE-PACKING MACHINE

Packaging system: Single bundler

Details:

High speed machine with a remarkably high quality of the final package.
The widest size range of its category.

Market sectors:

Food, Confectionery, Pharmaceutical, Cosmetic, Chemical, Magnetic, Paper, Tobacco

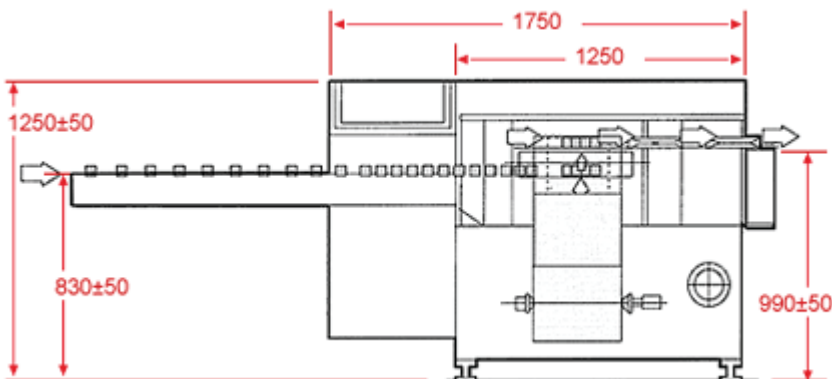

Technical informations

Mechanical speed 130 cycles/min.

Max. absorbed power: 2.5 kW

Weight of basic machine 900 Kg.

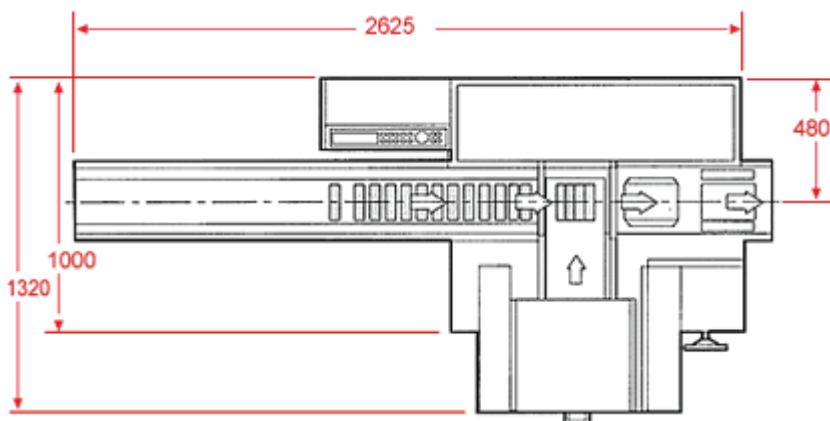

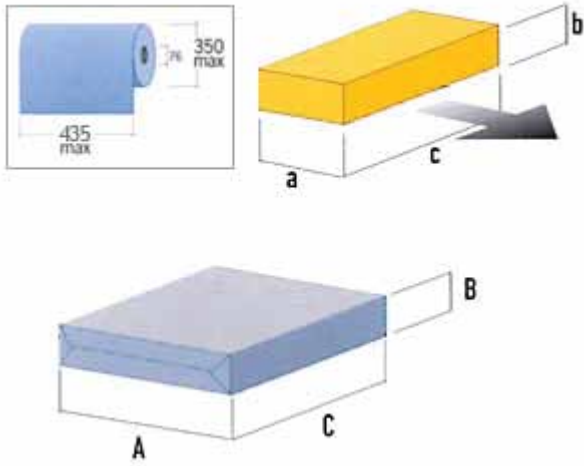

FORMAT LIMITS (mm)

	A	B	C
MIN	25	15	60
MIN	130	80	300

Modifications can be made for sizes exceeding the standard limit

ACCESSORIES	SERIES	OPTIONAL
INFEEED MAX LOAD CHECK	●	
END OF FILM REEL CHECK	●	
PRINT REGISTRATION		●
TEAR TAPE APPLICATION		●
ADDITIONAL REEL HOLDER		●
COUNTERS (PACKS, PRODUCTION HOURS, ETC)		●
DISPLAY + KEYBOARD FOR SETTING MACHINE FUNCTIONS	●	
LEAFLET INSERTING UNIT		●
INTERFACE OF MACHINE PLC WITH REMOTE UNIT		●
CODING UNITS		●
MULTIPACK INFEEED		●