



West Pharmaservices  
Process and Packaging Machinery Engineers



# Unipocket

CASE-PACKING MACHINE

Packaging system: Side-loading case packer

Details: A balcony designed and fully servodriven machine. An amazing synthesis of the most advanced technology and design in a minimal layout.

Market sectors:

Food, Confectionery, Pharmaceutical, Cosmetic, Chemical, Magnetic, Tobacco

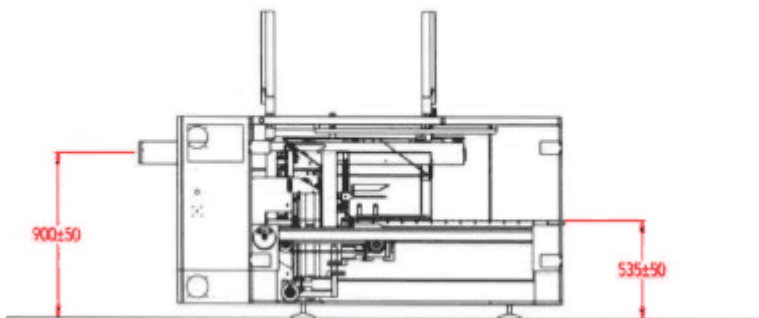

Technical information

Mechanical speed 14 cycles/min.

Max. compressed air consumption 2-4 NL/ciclo

Working pressure 6 BAR

Max. absorbed power:

with adhesive tape closure kW 3,5

with hot-melt closure kW 6,0

Weight of basic machine 1800 Kg.

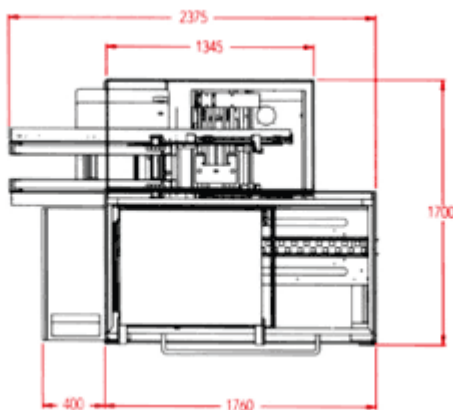

FORMAT LIMITS (mm)

CASE INTERNAL DIMENSIONS

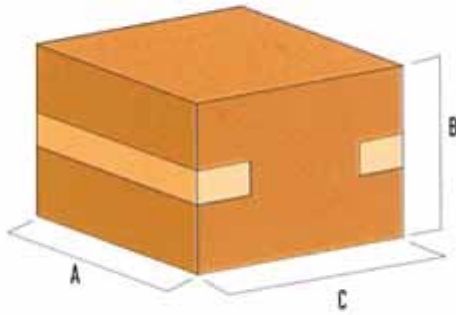

	A	B	C
MIN	200	130	110
MIN	550	350	350

Modifications can be made for sizes exceeding the standard limit

ACCESSORIES	SERIES	OPTIONAL
INFEEED MAX LOAD CHECK	●	
CASE MAGAZINE MIN LEVEL CHECK	●	
COUNTERS (PACKS,PRODUCTION HOURS,ETC.)	●	
UNIT FOR INSERTING CARDBOARD SHEET BETWEEN LAYER OF PRODUCT	●	
END OF ADHESIVE TAPE CHECK	●	
COMPLETE CASE CHECK		●
DISPLAY + KEYBOARD FOR SETTING MACHINE FUNCTIONS	●	
INTERFACE OF MACHINE PLC WITH REMOTE UNIT		●
CODING UNITS		●