



West Pharmaservices
Process and Packaging Machinery Engineers



Far Xe



CASE-PACKING MACHINES

Packaging system: bundling - overwrapping machine

Details: Fully electronic high stacking speed machine. By-pass option through simple belt (within the machine footprint) parallel to the wrapping station.

Market sectors: Food, Confectionery, pharmaceutical, Cosmetic, Chemical, Magnetic, Paper

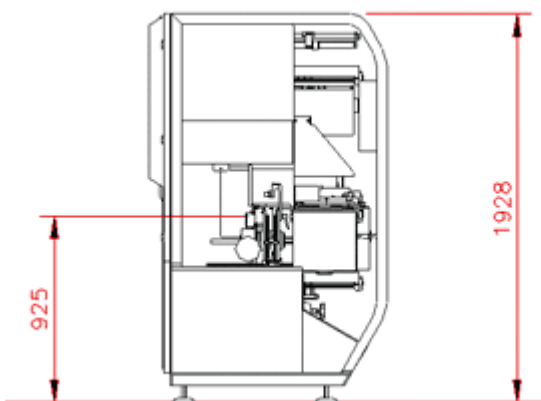

Technical information

Mechanical speed 100 cycles/min.

Max. absorbed power: 7.5 kW

Weight of basic machine 1800 Kg.

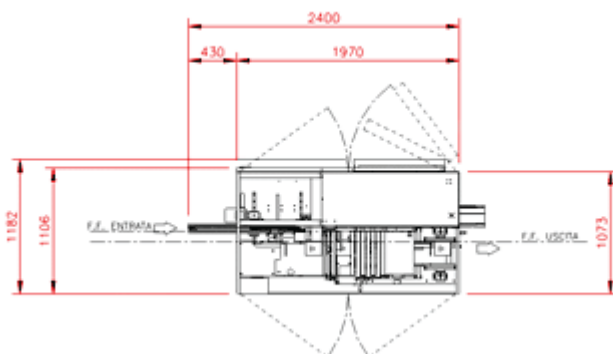

FORMAT LIMITS (mm)

PRODUCT

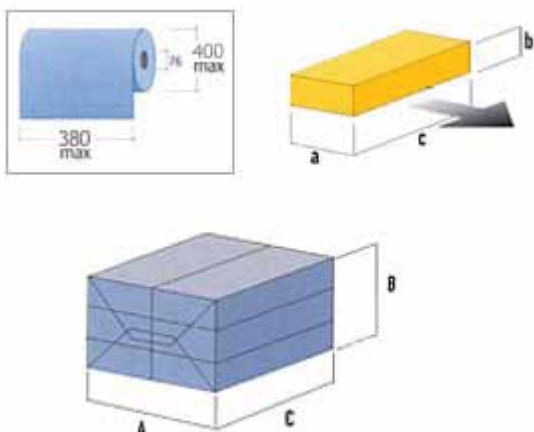

	A	B	C
MIN	15	10	50
MIN	250	60	210

BUNDLE

	A	B	C
MIN	50	20	50
MIN	250	150	210

Modifications can be made for sizes exceeding the standard limit

ACCESSORIES	SERIES	OPTIONAL
INFEEED MAX LOAD CHECK	●	
END OF FILM REEL CHECK	●	
PRINT REGISTRATION		●
TEAR TAPE APPLICATION		●
ADDITIONAL REEL HOLDER		●
COMPLETE BUNDLE CHECK		●
DISPLAY + KEYBOARD FOR SETTING MACHINE FUNCTIONS	●	
LEAFLET INSERTING UNIT		●
INTERFACE OF MACHINE PLC WITH REMOTE UNIT		●
COMBS FOR EMPTYING MACHINE AT END OF PRODUCTION	●	