



West Pharmservices

Process and Packaging Machinery Engineers



NERI SL 400 TE Tamper evident Labeller



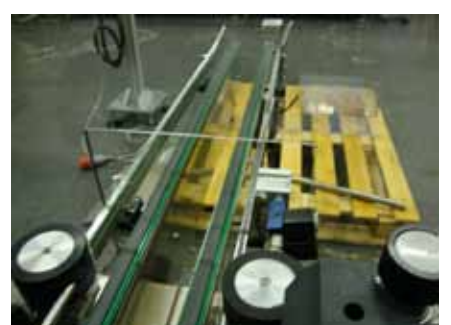
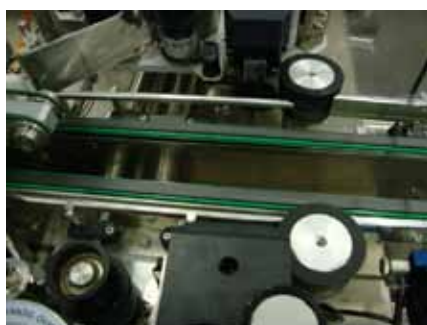
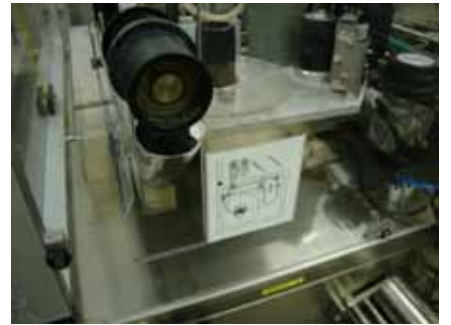
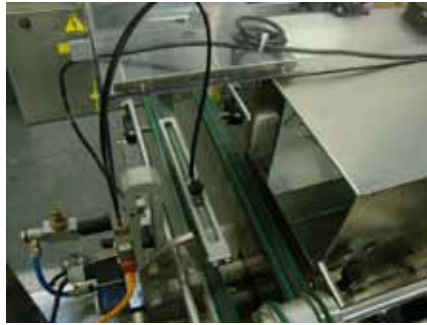
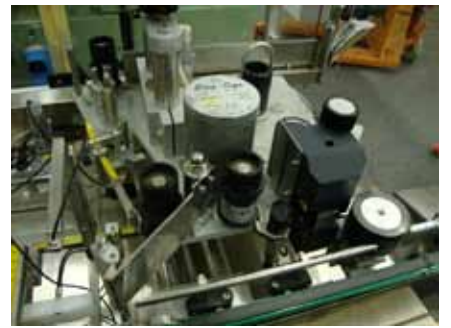

NERI SL 400 TE Labeller

Application of 2 self adhesive Tamper-Evident seals
on the closure corners of the formed cartons.

Vignette height 20 ÷ 60 mm
Vignette length 15 ÷ 80 mm
Seals height 15 ÷ 30 mm
Seals length 15 ÷ 60 mm
Maximum rate (Pcs/1') 500
Label speed 0 ÷ 50 mt/1'
Maximum reel diameter 400 mm
Reel core diameter 45 - 75 mm
Standard electric power supply 380 - 220 V 50Hz
Installed power 2,5 Kw
Compressed air pressure 7 Bar
Compressed air consumption 20 Nlt/h
Net Weight (Kg) 280 - 460 - 500 Kg

Carton Size Range (A) min. 20 - max. 120

Carton Size Range (B) min. 13 - max. 120

Carton Size Range (C) min. 65 - max. 250

Year of manufacture: 1993

Machine is in good condition and running prior to removal from site.

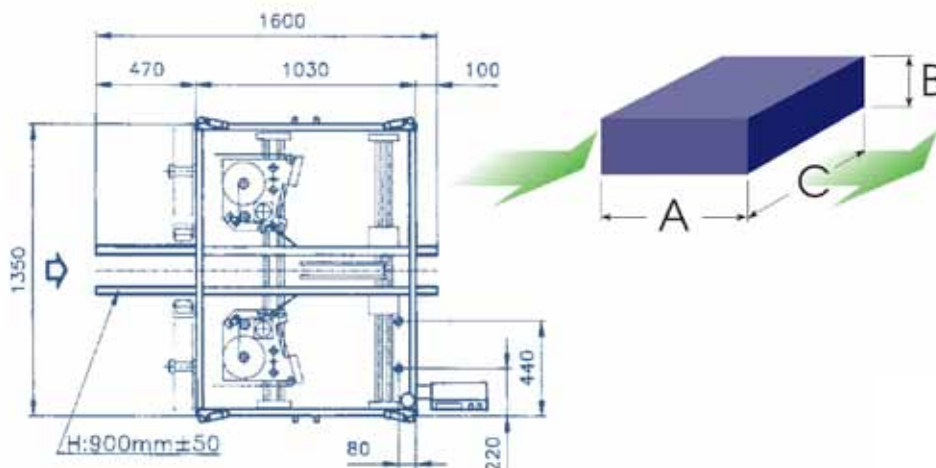

STOCK NUMBER
WP451017

Telephone: 01202 870890

www.westpharmaservices.co.uk